

ELECTRONIC IGNITION TRANSFORMERS FOR PERMANENT OPERATION

TC...S. Series

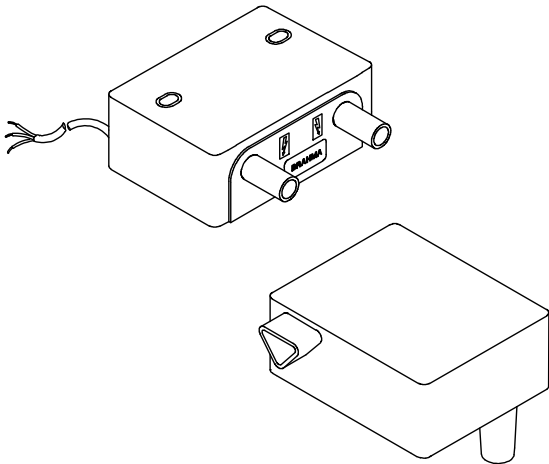

TD...S. Series

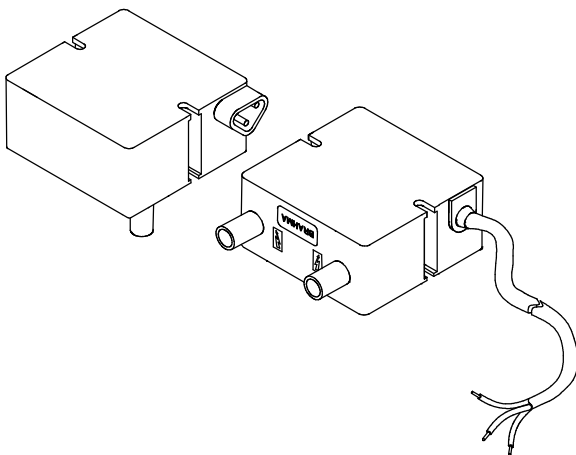

DESCRIPTION

These ranges of electronic ignition transformers are characterized by extremely limited overall dimensions and are particularly suitable to equip water cleaners, forced draught burners for gas and light or heavy oil, for civil and industrial applications.

The working principle is based on a high frequency electronic oscillator; the voltage it generates is then increased by using a transformer with ferrite nucleus, reaching in this way output voltage values up to 15 kV.

All types can be supplied with filter to minimize the emission of electromagnetic interference. In this way this series of electronic transformers is in compliance with the EMC directive 2014/30/EU without the use of external filters.

The transformers of this series can also be supplied for non-permanent operation (50% duty cycle in 2 minutes). For further information see relevant data sheets (TC...A. and TD...A.).

FEATURES

Followings are the main features of these ranges of transformers:

- available with inbuilt EMC filter;
- 100% duty cycle;
- limited weight and overall dimensions;
- high efficiency and ignition power;
- low consumption;
- single pole or double-pole high voltage output;
- different fixing and connecting systems;
- inbuilt protection against short circuit;
- **in oil and gas burners, the safety of ignition transformers depends on the control unit.**

APPROVALS

- The transformers comply with the essential requirements of the "Low Voltage Directive (LVD) 2014/35/EU", as they are approved by **IMQ** according to the product standards EN 61558-1:2005 + A1:2009 and EN 61558-2-3:2010.

Type	Voltage	Certificate no. 
TC1...S. TD1...S.	220-240 V 50/60 Hz	CA04.03571
TC2...S. TD2...S.	220-240 V 50/60 Hz	CA04.03572

- The transformers are also provided with "CB TEST CERTIFICATE No. IT-3904" stating their compliance with the international standards IEC 61558-1 (ed. 1) + am1 and IEC 61558-2-3 (ed. 1).
- The transformers type TCxxxxSx and TDxxxxSx 110-120 V, 50/60 Hz are also available in UL approved version with "Certificate Number 20100119-E331308" according to the standards "UL 506 Standard for Specialty Transformers, 13th Edition" and "C22.2 No. 13 Standard for Luminous Tube Signs, Oil or Gas Burner Ignition Equipment 1st Edition".

TECHNICAL DATA

	TC1...S - TC1...SF TD1...S - TD1...SF		TC2...S - TC2...SF TD2...S - TD2...SF	
	110-120	220-240	110-120	220-240
Number of poles	1		2	
Output peak voltage kV (1)	15		2x12	
Rated output voltage kV (4)	4.3	5.5	2 x (2.3 ÷ 2.5)	2 x (2.8 ÷ 3.3)
Output peak current mA (2)	45		55	
Rated output current mA (2)	14	15	20	20
Output voltage frequency kHz (1)	6		8.5	
Output voltage frequency kHz (2)	10		12	
Consumption VA (3)	25		30	

(1) No-load output and 30 pF load.

(2) Short circuit output.

(3) 10 mm spark gap.

(4) No-load output.

- **Supply voltage:** 220-240 V 50/60 Hz
on request: 110-120 V 50/60 Hz
- **Protection fuse:** The transformer must be powered through a fuse with F1A 250V features, in compliance with EN 60127
- **Duty cycle:** 100 %
- **Operating temperature range:** -10 ... +60 °C
- **Protection degree:** IP00
- **Winding class:** H
- **Recommended distance between the electrodes:** 3÷5 mm
- **Max. ignition cable length:** 1.5 m
- **Standard supply cable length:** 560 mm
- **Weight:** TC series 420 g approx.
TD series 360 g approx.

CONSTRUCTION

The working principle based on the use of a high frequency electronic oscillator has enabled to develop a device with limited dimensions and weight, but with high ignition power.

The electronic circuit and the transformer with ferrite nucleus are bathed in a special kind of resin with very good thermal conductivity and a specific coefficient of expansion, which ensures high resistance to temperature variations and to the overload due to protracted working.

An inbuilt varistor protects the device from possible voltage transients in the mains supply.

The transformers of these series are available in different versions as regards the number of poles, the position of the isolators, the type of connection, the power supply connection and the availability of an EMC filter; on this subject, see the following scheme:

TC/TD X X X X S X

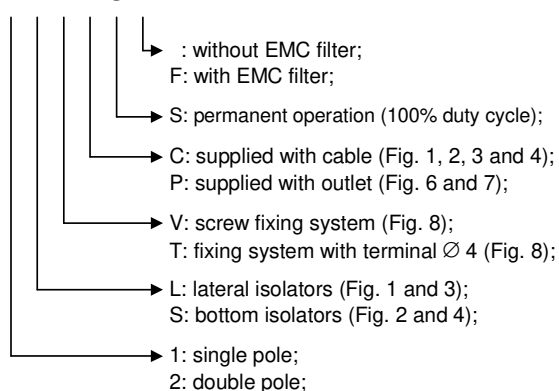

For instance, the designation TC2LVPSF indicates that the transformer belongs to the TC series, is provided with two lateral isolators, screw fixing system, power supply with outlet, EMC filter and is for permanent operation.

OVERALL DIMENSIONS

The TD series differs from the TC series for its more reduced overall dimensions; Fig. 1, Fig. 2, Fig. 3 and Fig. 4 show the main dimensions of both transformer series.

To fix the transformers, screws type M4 or M5 should be used (in the transformers of the TC series, the oval holes enable a variation of the fixing wheel base between 57 mm and 64 mm).

TC1L – TC2L

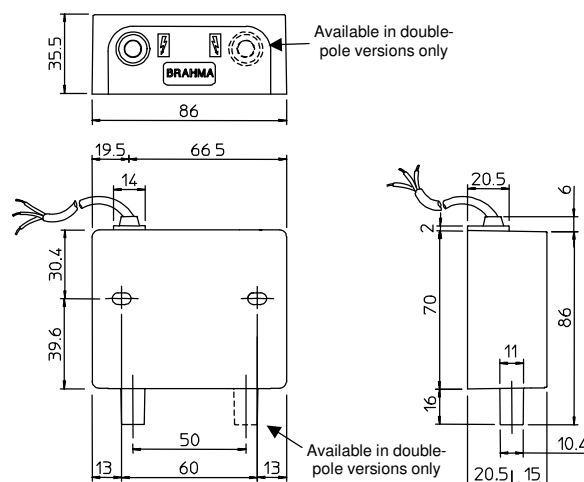

Fig. 1

TC1S – TC2S

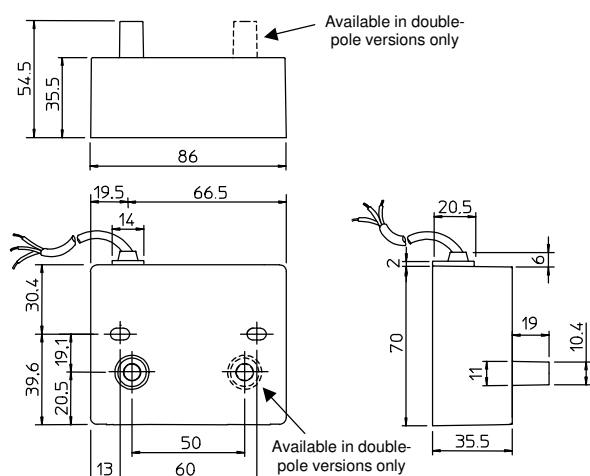

Fig. 2

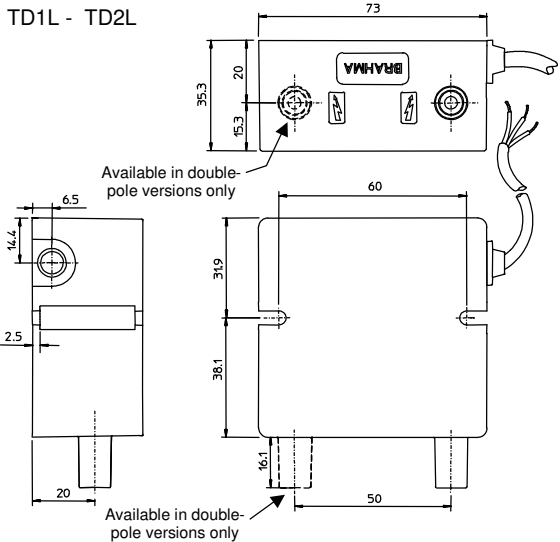

Fig. 3

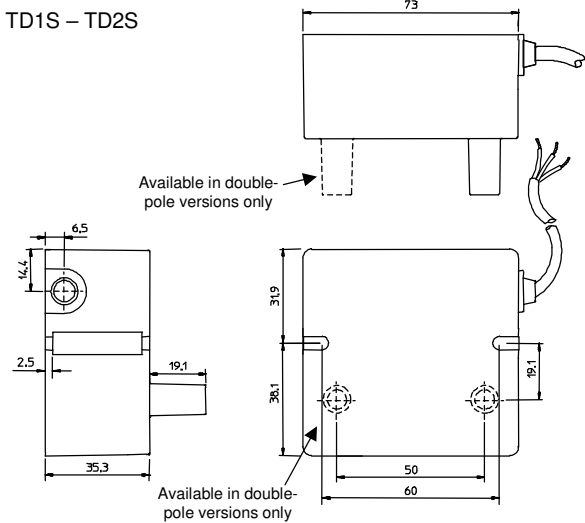

Fig. 4

CONNECTION

These ranges of ignition transformers have been developed in order to be used with control boxes of our own production, which can be mounted on the ignition devices by means of fixing screws type M4x45, as shown in Fig. 5. All transformers can be supplied with cable or supply outlet; see, for instance, Fig. 6 and Fig. 7, which show the dimensions of a transformer provided with supply outlet (with laterals isolators).

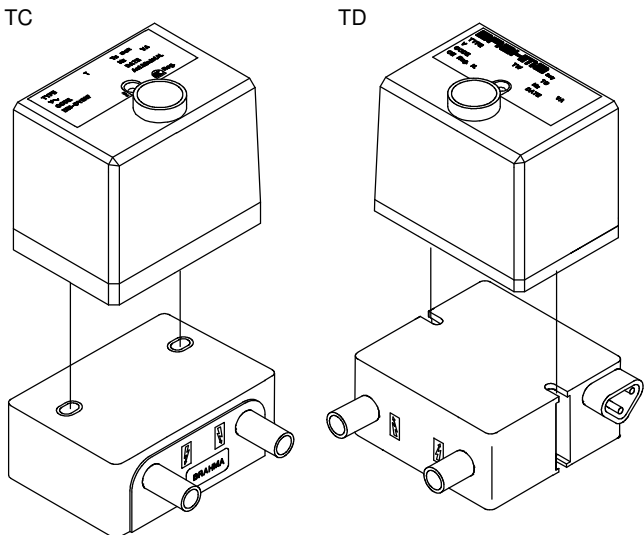

Fig. 5

TC

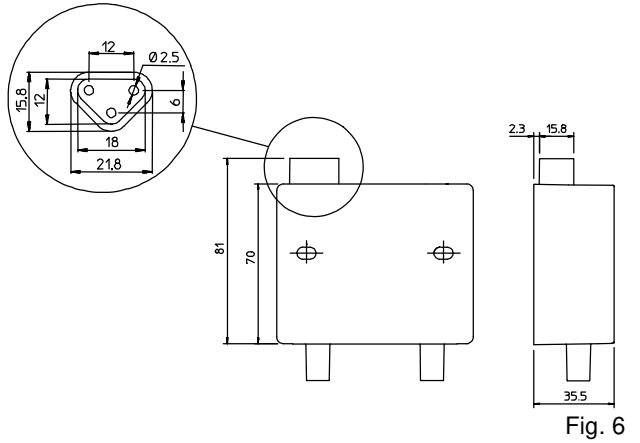

Fig. 6

TD

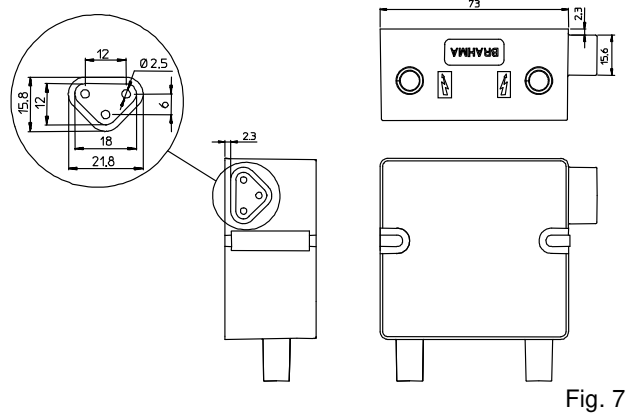

Fig. 7

The connection of high voltage cables can be of two types, according to the terminals used inside the isolators: connections can be carried out by means of a screw or of a cylindrical terminal with 4 mm diameter, as shown in Fig. 8. All connectors, including the ones complete with cable, can be supplied on request.

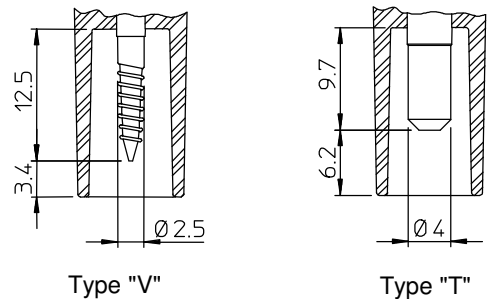

Fig. 8

INSTALLATION



- Caution! There might be dangerous voltages.
- Connect and disconnect the ignition transformer only after interrupting the mains supply.
- Respect the applicable national and European standards (e.g. EN 60335-1 / EN 60335-2-102) regarding electrical safety.
- Make sure that the earth of the ignition transformer and the earth of the electrical system are well connected.
- The device can be mounted in any position.
- Avoid putting high voltage cables next to other cables.
- Ensure a protection degree suitable to the application.

EMC FILTER

With particular reference to the use of ignition transformers in oil or gas burners, you will find here below some remarks about the application of these devices, resulting from the research carried out by the Brahma Test Laboratory. This Laboratory, in compliance with EN 55014-1, is adequately equipped for the measuring of electromagnetic interference in boilers, burners, hot air generators and heating systems in general.

According to the EMC directive 2014/30/EU, the above mentioned products must be subjected to the measuring of conducted electromagnetic interference in the mains supply, irradiated by the supply cable; the measuring is carried out on the basis of a frequency range from 150 kHz to 30 MHz in case of conducted interference, and from 30 to 300 MHz in case of irradiated interference.

Electromagnetic interference is mainly due to power variations in the electric circuits (i.e. current peaks); the greater and faster these variations, the higher the interference. In the case we are considering, the main source of interference is the discharge of the ignition transformer: the irregular discharge current causes the emission of interference on a wide frequency range.

To keep the products within the limits allowed by the present standards, a special capacitive-inductive filter is generally installed in series to the mains supply, in order to reduce electromagnetic interference with frequency up to 20 MHz approx. For the frequency range beyond this limit, it is useful to mount a resistor of a few k Ω s in series to the ignition electrode, as in this case the interference is due to the high current peak generated whenever an electric arc is produced. The stronger the stray capacitance between ignition electrodes and cables and burner metal casing, the higher the current peak. The above mentioned resistor has the function of keeping the current peak as low as possible; the closer to the source of electric discharge, the greater the effectiveness of the resistor. Besides the obvious advantage of reduced assembly costs, the fitting of an EMC filter inside the ignition transformer ensures the elimination of electromagnetic interference in close proximity to their source, without involving the remaining electric circuit.

Finally, the following solutions are always effective to reduce the emission of electromagnetic interference:

- ignition cables should be as short as possible (this will reduce their stray capacitance and their possibility of acting as antennas, transferring electromagnetic interference to the nearby cables);
- use distributed resistance cables or mount a resistor near the electrodes (few k Ω s can reduce the current peak);
- let ignition cables follow a separate path, close to ground planes (this will reduce the influence of electromagnetic interference on the remaining electric cables);
- make a single earth centre, preventing the earth conductors from creating circular paths.



NOTES ABOUT PRODUCT DISPOSAL

The device contains electronic components and cannot therefore be disposed of as normal household waste. For the disposal procedure please refer to the local rules in force for special waste.

ATTENTION ->Company Brahma S.p.A. declines any responsibility for any damage resulting from the Customer's interfering with the device.

BRAHMA S.p.A.

Via del Pontiere,31

37045 Legnago (Vr)

Tel. +39 0442 635211 – Telefax +39 0442 25683

[http:// www.brahma.it](http://www.brahma.it)

E – mail: brahma@brahma.it

09/02/2022 Subject to amendments without notice