



Burner Controls

LGB...

Burner controls for the supervision of 1- or 2-stage gas or gas / oil burners of small to medium capacity (typically up to 350 kW), with or without fan, in intermittent operation.

The LGB... and this Data Sheet are intended for use by OEMs which integrate the burner controls in their products!

Use

The LGB... burner controls are used for the startup and supervision of 1- or 2-stage gas or gas / oil burners in intermittent operation.

Depending on the type of burner control used, the flame is supervised either by an ionization probe, a blue-flame detector QRC1... for forced draft gas / oil burners, or a UV detector QRA... (with auxiliary unit AGQ1...A27).

In connection with the respective adapters, the LGB... burner controls replace their predecessor types LFI7... and LFM1... (also refer to «Replacement types» under «Ordering»).

- Automatic forced draft burners for gaseous fuels to EN 676
- Gas burner controls to EN 298
- Undervoltage detection
- Air pressure supervision with function check of the air pressure switch during startup and operation
- Electrical remote reset facility
- LGB41... for use with atmospheric gas burners

Warning notes



To avoid injury to persons, damage to property or the environment, the following warning notes should be observed!

Do not to open, interfere with or modify the unit!

- All activities (mounting, installation and service work, etc.) must be performed by qualified staff
- Before performing any wiring changes in the connection area of the LGB..., completely isolate the burner control from the mains supply (all-polar disconnection)
- Ensure protection against electric shock hazard by providing adequate protection for the burner control's connection terminals
- Each time work has been carried out (mounting, installation, service work, etc.), check to ensure that wiring is in an orderly state and make the safety checks as described in «Commissioning notes»
- Check to ensure that wiring is in an orderly state
- Press the lockout reset button only manually (apply a force of no more than 10 N), without using any tools or pointed objects
- Fall or shock can adversely affect the safety functions. Such units must not be put into operation, even if they do not exhibit any damage

Mounting notes

- Ensure that the relevant national safety regulations are complied with

Installation notes

- Always run the ignition cables separate from the unit and other cables while observing the greatest possible distance
- Do not mix up live and neutral conductors
- Install switches, fuses, earthing, etc., in compliance with local regulations
- Ensure that the maximum permissible current ratings will not be exceeded (refer to «Technical data»)
- Do not feed external mains voltage to the control outputs of the unit. When testing the devices controlled by the burner control (fuel valves, etc.), the LGB... must not be connected
- To isolate the burner control from the mains supply, use an all-polar switch with a contact gap of at least 3 mm
- Secure the earthing lug in the base with a metric screw and a lockwasher
- In the case of burners with no fan, the AGK25 must be connected to terminal 3 as a burden, or else the burner cannot reliably start
- For safety reasons, feed the neutral conductor to the neutral distributor in the plug-in base, or to terminal 2. Connect the burner components (fan, ignition transformer and gas valves) as represented in the figure 7435a14, to the neutral distributor as shown below. The connection between neutral conductor and terminal 2 is pre-wired in the base

Example

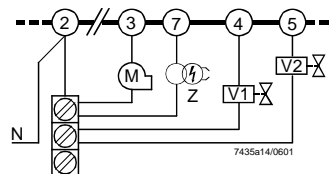

Legend

- V... Fuel valve
- M Fan motor
- Z Ignition transformer

Correct wiring of neutral conductors!

Electrical connection of flame detectors

It is important to achieve practically disturbance- and loss-free signal transmission:

- Never run detector cables together with other cables
 - Line capacitance reduces the magnitude of the flame signal
 - Use a separate cable
- Observe the permissible length of the detector cables (refer to «Technical data»)
- The ionization probe and the ignition electrode are not protected against electric shock hazard
- Locate the high-voltage ignition electrode and the ionization probe such that the ignition spark cannot arc over to the ionization probe (risk of electrical overloads) and that it cannot adversely affect the supervision of ionization
- With both ionization current and UV supervision, the cable length for flame detection must not exceed 20 m
- Insulation resistance
 - Must be a minimum of 50 MΩ between ionization probe and ground
 - Soiled detector holders reduce the insulation resistance, thus supporting creepage currents
 - Prerequisite is not only high-quality heat-resistant insulation of the probe's cable, but also of the ionization probe itself (ceramic holder)
- Earth the burner in compliance with the relevant regulations; earthing the boiler alone does not suffice
- The connection diagrams show the burner controls with earthed neutral conductor. In networks with nonearthed neutral conductor and ionization current supervision, terminal 2 must be connected to the earth conductor via an RC unit (type reference ARC 4 668 9066 0). It must be made certain that local regulations are complied with (e.g. protection against electric shock hazard) since AC 230 V / 50 Hz mains voltage produces peak leakage currents of 2.7 mA

Commissioning notes

- When commissioning the plant for the first time or when doing maintenance work, make the following safety checks:

	Safety check to be carried out	Anticipated response
a)	Burner startup with previously interrupted line to the ionization probe and flame detector darkened in the case of QRA... or QRC1...	Lockout at the end of «TSA»
b)	Burner operation with simulated loss of flame. For that purpose, cut off the gas supply (e.g. disconnect the fuel valve while ensuring protection against electric shock hazard)	Immediate lockout
c)	Burner operation with simulated air pressure failure (not with atmospheric burners)	Immediate lockout

Standards and certificates



Conformity to EEC directives
 - Electromagnetic compatibility EMC (immunity)
 - Low-voltage directive
 - Directive for gas appliances

89 / 336 / EEC
 73 / 23 / EEC
 90 / 396 / EEC



ISO 9001: 2000
 Cert. 00739



ISO 14001: 2004
 Cert. 38233

- Identification code to EN 298
 - LGB21... / LGB22...
 - LGB32...
 - LGB41...
 - («BV1 + BV2» or «ZBV + BV2»)

F T L L X N with 2-stage operation
F M L L X N with 2-stage operation
A B L L X N with 2-stage operation
A M L L X N with 1-stage operation

LGB21.130A17	x	x	---	---
LGB21.130A27	x	x	x	x
LGB21.230A27	x	x	x	---
LGB21.330A27	x	x	x	---
LGB21.350A17	x	x	---	---
LGB21.350A27	x	x	x	x
LGB21.550A27	x	x	x	x
LGB22.130A27	x	x	x	x
LGB22.230B27	x	x	x	---
LGB22.330A17	x	x	---	---
LGB22.330A27	x	x	x	x
LGB22.330A270	x	x	x	---
LGB32.130A27	x	x	x	x
LGB32.230A17	x	x	---	---
LGB32.230A27	x	x	x	---
LGB32.330A17	x	x	x	---
LGB32.330A27	x	x	x	---
LGB32.350A17	x	x	x	---
LGB32.350A27	x	x	x	x
LGB41.255A27	x	x	---	x
LGB41.258A17	x	x	---	---
LGB41.258A27	x	x	---	x

Service notes

- Use KF8872 service adapter for short periods of time only

Disposal notes



The unit contains electrical and electronic components and must not be disposed of together with household waste.
 Local and currently valid legislation must be observed.

Mechanical design

The housing is made of impact-proof, heat-resistant and flame-retarding plastic. It is of plug-in design (measuring 91 x 62 x 63 mm, including the base) and engages audibly in the base.

The housing accommodates the

- programming mechanism with the synchronous motor
- electronic flame signal amplifier (ionization) with the flame relay and the other switching devices
- lockout reset button with its integrated fault indication lamp

Type summary

The type references given below apply to LGB... burner controls without plug-in base and without flame detector. For ordering information on plug-in bases and other accessories, refer to «Mechanical design», «Ordering», «Flame supervision ...» and «Technical data».

Flame detector	Type reference	Approved in:	tw/s	t1/s	TSA/s	t3n/s	t3/s	t4/s	t9/s 6)	t10/s	t11/s 3)	t12/s 3)	t20/s
			ca.	min.	max.	ca.	ca.	ca.	max.	min.	max.	max.	ca.
Burner controls for 2-stage burners without control of actuator													
Ionization probe (ION) or UV detector QRA... with AGQ1...A27	LGB21.130A27 4)7)	CH, EU, S, SF	8	7	3	2.4	2	8	---	5	---	---	6
	LGB21.230A27 5)	CH, EU, S, SF	8	15	3	2.4	2	8	---	5	---	---	38
	LGB21.330A27 5)	CH, EU, H, S, SF	8	30	3	2.4	2	8	---	5	---	---	23
	LGB21.350A27 5)7)	CH, EU, H, S, SF	8	30	5	4	2	10	---	5	---	---	21
	LGB21.550A27 5)	AUS, CH, EU	8	50	5	4	2	10	---	5	---	---	2
Burner controls for 2-stage burners with control of actuator													
Ionization probe (ION) or UV detector QRA... with AGQ1...A27	LGB22.130A27 4)	CH, EU, N, S	9	7	3	2.4	3	8	---	4	12	12	21
	LGB22.230B27 5)	CH, EU, N, S, SF	9	20	3	2.4	3	8	---	4	16.5	16.5	2
	LGB22.330A27 5)7)	AUS, CH, EU, H, N, S, SF	9	30	3	2.4	3	8	---	4	12	11	2
	LGB22.330A270 5)8)	EU	9	30	3	2.4	3	8	---	4	12	11	2
Blue-flame detector QRC1...	LGB32.130A27 4)1)	CH, EU	9	7	3	2.4	3	8	---	4	12	12	21
	LGB32.230A27 5)1)	CH, EU	9	20	3	2.4	3	8	---	4	12	12	2
	LGB32.330A27 5)	CH, EU	9	30	3	2.4	3	8	---	4	12	11	2
	LGB32.350A27 5)	CH, EU	9	30	5	4.4	1	10	---	4	12	9	2
Burner controls for atmospheric burners													
Ionization probe (ION) or UV detector QRA... with AGQ1...A27	LGB41.255A27	EU	18	---	5	4	2	10	5	---	---	---	10
	LGB41.258A27 2)5)7)	CH, EU, H, SF	18	---	5	4	2	10	8	---	---	---	10

Legend	tw	Waiting time
	t1	Prepurge time
	TSA	Ignition safety time
	t3	Preignition time
	t3n	Postignition time
	t4	Interval «BV1-BV2» or «BV1-LR»
	t9	Second safety time
	t10	Specified time for air pressure signal
	t11	Programmed opening time for actuator «SA»
	t12	Programmed closing time for actuator «SA»
	t20	Interval up to self-shutdown of programming mechanism

- 1) On request
- 2) For atmospheric burners up to 120 kW
- 3) Maximum running time available for actuator
- 4) Also suited for flash steam generators
- 5) Also suited for stationary direct-fired air heaters
- 6) «t9» + reaction time of flame relay
- 7) Also available for AC 100...110 V; in that case, the last 2 digits read ...17 in place of ...27
- 8) Without internal microfuse; must only be used in connection with external microfuse 6.3 A (slow)!

Burner control, without plug-in base refer to «Type summary»

Connection accessories for small burner controls refer to Data Sheet N7201

- Plug-in base AGK11...
- Cable holders AGK65..., AGK66, AGK67...
- Cable strain relief elements for AGK67...

Connection accessories for small burner controls refer to Data Sheet N7203

- Plug-in base AGK13...
- Plug-in housing AGK56
- Accessories AGK68

Flame detectors

- Ionization probe supplied by thirds
- UV- flame detectors QRA2... / QRA10... refer to Data Sheet N7712
- Blue-flame detectors QRC1... refer to Data Sheet N7716



RC unit **ARC 4 668 9066 0**

For the supervision of ionization currents in networks with nonearthed neutral conductor



PTC resistor (AC 230 V) **AGK25**

To burden terminal 3 (mandatory when using burners with no fan motor connected to terminal 3)



Auxiliary unit for UV supervision

- Cable length 500 mm **AGQ1.1A27**
- Cable length 300 mm **AGQ1.2A27**
- Can be fitted under the plug-in base (refer to «Dimensions»)



Pedestal (empty housing) **AGK21**

- For increasing the height of the LGB... to that of the LFM... or LFI7...







Service adapter **KF8872**

- For checking the functioning of the burner controls on the burner plant
- Functional test with signal lamps
- Detector resistance measurement with a jack of 4 mm diameter

Adapters / replacement types

No rewiring required

LGB21... with adapter	KF8852		LFI7...
	KF8880		LFM1... ¹⁾ LFM1...-F ¹⁾
LGB22... with adapter	KF8853-K		LFI7...
	KF8880		LFM1... ¹⁾
LGB41... with adapter	KF8862		LFM1... ¹⁾

¹⁾ Designed only for ionization

Technical data

General unit data LGB...	Mains voltage	AC 220 V -15 % ...AC 240 V +10 % (LGB2... / LGB4...) AC 230 V -15 % / +10 % (LGB32...!) AC 100 V -15 % ...AC 110 V +10 %
	Mains frequency	50...60 Hz ±6 %
	Input current at terminal 12	max. 5 A within the permissible voltage range AC 187...264 V or AC 195...253 V
	Current rating	
	- Terminal 3	max. 3 A (15 A for max. 0.5 s) max. 2 A
	- Terminals 4, 5 and 7	max. 1 A
	- Terminals 9 and 10	max. 5 A
	- Terminal 12	(at U _{max} . AC 264 V or AC 253 V)
	Cable length terminals 8 and 10	20 m at 100 pF / m
	Perm. cable lengths	max. 3 m at 100 pF / m line capacitance
	Detector cable laid separately	20 m
	Power consumption	3 VA
	Primary fuse	max. 10 A (slow)
	Degree of protection	IP 40, when built in, with the exception of the connection area (terminal base)
	Mounting position	optional
	Weight	approx. 230 g
Environmental conditions	Storage	DIN EN 60 721-3-1
	Climatic conditions	class 1K3
	Mechanical conditions	class 1M2
	Temperature range	-20...+60 °C
	Humidity	< 95 % r.h.
	Transport	DIN EN 60 721-3-2
	Climatic conditions	class 2K3
	Mechanical conditions	class 2M2
	Temperature range	-20...+60 °C
	Humidity	< 95 % r.h.
	Operation	DIN EN 60 721-3-3
	Climatic conditions	class 3K3
	Mechanical conditions	class 3M2
	Temperature range	-20...+60 °C
	Humidity	< 95 % r.h.



Condensation, formation of ice and ingress of water are not permitted!

Flame supervision

Flame supervision with ionization probe

	At mains voltage UN = AC 230 V
Detector voltage across terminals 1 and 2 or ground (AC voltmeter $R_i \geq 10 \text{ M}\Omega$)	$\leq U_N$
Detector current required for reliable operation	min. $3 \mu\text{A}$
Possible detector current in operation	max. $100 \mu\text{A}$

The conductivity and rectifying effect of hot flame gases are used for flame supervision. For that purpose, AC voltage is applied to the heat-resistant ionization probe which projects into the flame. The current that flows in the presence of a flame (ionization current) produces the flame signal which is fed to the input of the flame signal amplifier. The amplifier is designed such that it only responds to the DC current component of the flame signal, thereby ensuring that a short-circuit between ionization probe and ground cannot simulate a flame signal (since in that case AC current would flow).

Basically, the flame supervision circuit is insensitive to adverse effects of the ignition spark.

However, should the disturbing effects of the ignition spark on the ionization current exceed a certain level, the electrical connections on the primary side of the ignition transformer must be changed and / or the location of the ionization probe must be checked.

Ionization current supervision with burner controls operating on AC 110 V

Since the ionization current with burner controls operating on AC 110 V is only about 50 % of those operating on AC 230 V, certain applications make it necessary to increase the ionization current with a transformer.

Capacity of transformer: Min. 2 VA

Transforming ratio: Approx. 1.1...1.5

The primary and secondary windings of the transformer must be galvanically separated.

Connection of transformer

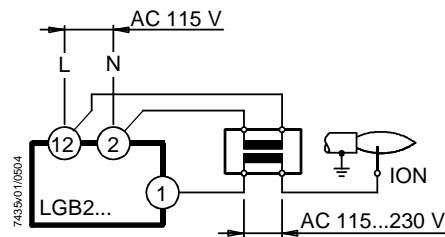

Flame supervision with
blue-flame detector
QRC1...

Perm. detector current during the prepurge time (dark current) max. 5 μ A

Detector current required during operation min. 50 μ A

Possible detector current in operation max. 80 μ A

Measuring circuit with the QRC1...

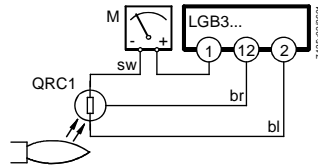

Legend

M Microammeter Ri max. 5000 Ω
sw Black wire
br Brown wire
bl Blue wire

The QRC1... has been designed specifically for blue-burning flames. Incidence of light is from the front and laterally. The flame detector is secured by means of a soft plastic plug. 3-core connection (preamplifier integrated in the detector casing). For the different types of flame detectors, engineering notes and technical data, refer to Data Sheet N7716.

Flame supervision with
UV detector QRA... and
AGQ... for LGB21... /
LGB22... / LGB41...

Mains voltage AC 220 V -15% ...AC 240 V $+10\%$

Mains frequency 50...60 Hz $\pm 6\%$

Power consumption 4.5 VA

Degree of protection IP 40

Perm. ambient temperature

- In operation $-20\text{...}+60\text{ }^\circ\text{C}$

- During transport and storage $-40\text{...}+70\text{ }^\circ\text{C}$

Perm. length of cable from QRA... to max. 20 m

AGQ1...A27 (use separate cable)

Mounting position optional

Perm. length of connecting cable from max. 20 m

AGQ1...A27 to LGB...

Weight of AGQ1...A27 approx. 140 g

	At mains voltage UN:	
	AC 220 V	AC 240 V
Detector voltage at QRA... (with no load)		
Up to the end of «t10» and after controlled shutdown	DC 400 V	DC 400 V
From the beginning of «t1»	DC 300 V	DC 300 V
Detector voltage		
Load by DC measuring instrument Ri > 10 MΩ		
Up to the end of «t10» and after controlled shutdown	DC 380 V	DC 380 V
From the beginning of «t1»	DC 280 V	DC 280 V
DC detector signals with UV detector QRA...		
	Min. required	Max. possible
Measurement on the QRA...	200 μ A	500 μ A

Flame supervision with UV detector QRA... and auxiliary unit AGQ... for LGB21... / LGB22... / LGB41...

UV detector QRA... Universal flame detector for use with gas and gas / oil burners. Incidence of light from the front and laterally, total length 97 mm. Available with normal or, as QRA2M, with higher sensitivity. Secured with flange and clamp. Also available as a metal encapsulated version in the form of the QRA10... (for details, refer to Data Sheet N7712).

Auxiliary unit AGQ1...A27 A special UV auxiliary unit AGQ1...A27 is required in connection with LGB... burner controls.

That unit is to be connected to the mains supply via 2 cables, and to the burner control via terminals 1, 2 and 11.

Using circuitry (A) or (B), there are 2 ways to make the quench test on aging UV detectors and to detect UV light:

1. (A) Operation with a permanent line:
UV test at a higher supply voltage across the UV cell on startup and after controlled shutdown.
2. (B) Operation with a controlled line:
UV test at a higher supply voltage only on startup, that is, during the interval between controlled startup and air pressure signal.
 - No voltage at the UV cell after controlled shutdown
 - No full substitute for mode (A) above, since an aged UV cell can regenerate itself

Measuring circuit

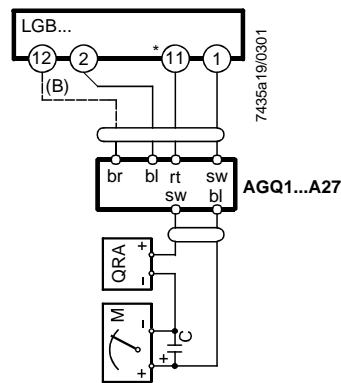

Connection diagram

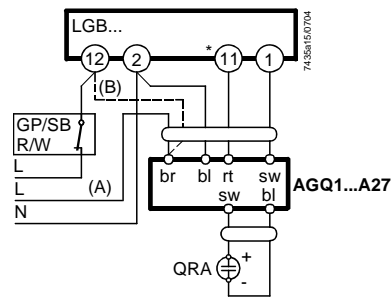

Measurement made on the flame detector

Legend

- GP Gas pressure switch
- R Temperature or pressure controller
- SB Safety limit thermostat
- W Limit thermostat or pressure switch
- * With LGB41...: Terminal 3
- (A) Operation with permanent line
- (B) Operation with controlled line

Functions

The function diagrams show the required or permissible input signals to the control section and to the flame supervision circuit hatched (refer to «Connection diagrams»). If these input signals are not present, the burner control will stop the startup sequence to trigger lockout where required by safety regulations.

Preconditions for burner startup

- Burner control must be reset
- The contacts of gas pressure switch «GP», limit thermostat / pressure switch «W», control thermostat / pressurestat «R» and safety limit thermostat «SB» must be closed
- Fan motor «M» or AGK25 must be connected
- Air pressure switch «LP» must be in its no load position

Undervoltages

LGB... burner controls are capable of detecting **undervoltages**. This means that load relay «AR» will be deenergized if mains voltage drops below AC 160 V (for nominal AC 220...240 V) or AC 75 V (for nominal AC 100...110 V). The burner control will automatically make a restart attempt when the supply voltage returns to a level above AC 160 V and AC 75 V respectively.

Reversed polarity protection

If the connections of live conductor (terminal 12) and neutral conductor (terminal 2) are mixed up, the burner control will initiate lockout at the end of «TSA».

Startup sequence

A – C Startup sequence

A **Start command** (switching on)

This command is triggered by control thermostat / pressurestat «R». Terminal 12 receives voltage and the programming mechanism starts running. On completion of waiting time «tw» with the LGB21..., or after air damper «SA» has reached the nominal load position (on completion of «t11») with the LGB22... / LGB32..., fan motor «M» will be started.

TSA **Ignition safety time**

On completion of «TSA», a flame signal must be present at terminal 1. That flame signal must be continuously available until shutdown occurs, or else flame relay «FR» will be deenergized, resulting in lockout.

tw **Waiting time**

During the waiting time, air pressure switch «LP» and flame relay «FR» are tested for correct contact positions.

t1 **Prepurge time**

Purging the combustion chamber and the secondary heating surfaces: Required with low-fire air volumes when using the LGB21... and with nominal load air volumes when using the **LGB22... / LGB32...** «Type summary» and the «Function and sequence diagrams» show the so-called **prepurge time «t1»** during which air pressure switch «LP» must indicate that the required air pressure is available. The effective prepurge time «t1» comprises interval end «tw» through «t3».

t3 **Preignition time**

During «t3» and up to the end of «TSA», flame relay «FR» is forced to close. On completion of «t3», the release of fuel is triggered at terminal 4 or at terminal 11 of the LGB41...

- t3n **Postignition time**
 Ignition time during «TSA»
 Just before reaching the end of «TSA», ignition transformer «Z» will be switched off.
 This means that «t3n» is somewhat shorter than «TSA».
 This is necessary in order to give the forcedly closed flame relay «FR» sufficient time to drop out if there is no flame.
- t4 **Interval**
LGB21... / LGB41...: Time to the release of the second fuel valve «BV2»
LGB22... / LGB32...: On completion of «t4», the heat source is controlled depending on the load (release of load controller «LR»)
- t9 **Second safety time**
 (Only with LGB41...)
 For pilot burners with main flame supervision equipped with a pilot gas valve «ZV1».
- t10 **Specified time for air pressure signal**
 On completion of this period of time, the set air pressure must have built up, or else lockout will occur.
- t11 **Programmed opening time for actuator «SA»**
 (Only with LGB22... / LGB32...)
 The air damper opens until the nominal load position is reached. Only then will fan motor «M» be switched on.
- t12 **Programmed closing time for actuator «SA»**
 (Only with LGB22... / LGB32...)
 During «t12», the air damper travels to the low-fire position.
- B – B' **Interval for establishment of flame**
- C **Burner operating position reached**
- C – D **Burner operation** (generation of heat)
 Nominal output or, in connection with a load controller «LR», part load operation.
- D **Shutdown by «R»**
 The burner is immediately shut down and the programming mechanism is ready for a new start.

Control sequence in the event of fault

In principle, whenever lockout occurs, the fuel supply will immediately be shut down. If that takes place between startup and preignition, which is not indicated by a symbol, the usual cause is air pressure switch «LP» shutting down, or a premature, faulty flame signal.

• After a mains failure or in the event of undervoltage:	New startup with full program sequence on power restoration
• Premature flame signal from the start of «t1»:	Immediate lockout
• Contacts of air pressure switch «LP» have welded during «tw»:	Prevention of startup
• No air pressure signal:	Lockout on completion of «t10»
• Air pressure failure on completion of «t10»:	Immediate lockout
• Burner does not ignite:	Lockout on completion of «TSA»
• Flame is lost during operation:	Immediate lockout

Lockout

After lockout, the LGB... will remain locked (lockout cannot be changed). This state will also be maintained in the event of mains voltage failure.

Resetting the LGB...

Whenever lockout occurs, the burner control can immediately be reset.

Lockout and control sequence indication

The position of the programming mechanism can be seen through the viewing window on the front of the unit. In the event of fault, the programming mechanism stops and thus the lockout indicator also. The symbol in the viewing window indicates both the position in the control sequence and the type of fault according to the following legend:

◀	No startup since the start control loop is open
	Interval «tw» or «t10» (LGB21...) Interval «tw» or «t11» (LGB22... / LGB32...) Interval «tw», «t3» or «TSA» (LGB41...)
▲	Air damper fully open (LGB22... / LGB32...)
P	Lockout due to absence of air pressure signal
◀◀◀	Interval «t1», «t3» and «TSA» (LGB21...) Interval «t1», «t3» («t12») (LGB22... / LGB32...)
▼	Release of fuel
1	Lockout since there is no flame signal on completion of the first safety time
2	Release of second fuel valve (LGB21... / LGB41...) Release of load controller (LGB22... / LGB32...)
3	Lockout since there is no flame signal on completion of the second safety time (LGB41...)
●●●●	Partial load or nominal load operation (or return to the operating position)

Connection diagrams

LGB21...

Burner controls for 1- or 2-stage forced draft burners.

Air damper control for prepurging with **low-fire air volume**.

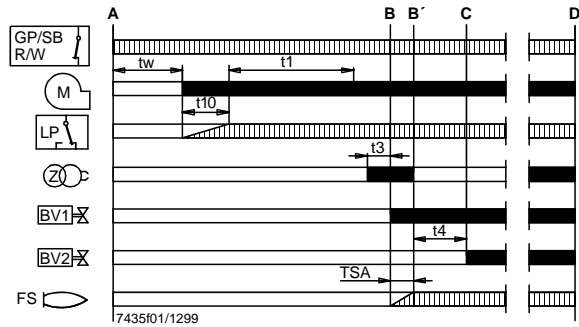

Application examples

Control of actuators of 2-stage or 2-stage modulating burners.

Prepurging («t1») with low-fire air volume.

Same low-fire actuator position (switching cam III) during startup and operation!

For information about actuators «SA»:

SQN3...: Refer to Data Sheet N7808

SQN7...: Refer to Data Sheet N7804

SQN9...: Refer to Data Sheet N7806

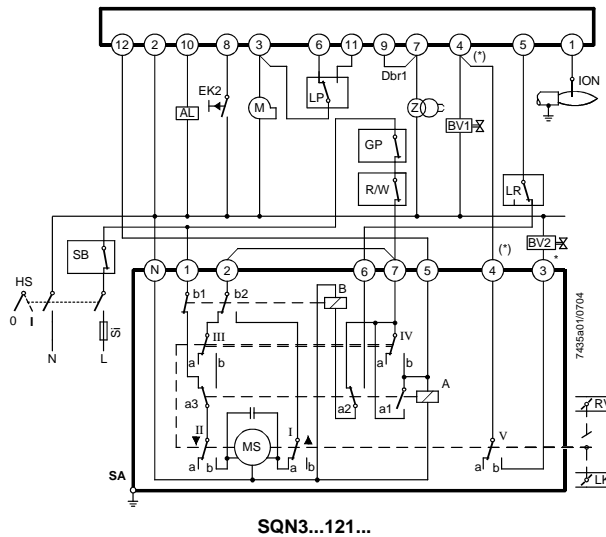

SQN3...121...

* Note:

With 2-stage modulating burners (with gas control damper «RV»), «BV2» and the dotted connection between terminals (*) are not required

Flame supervision

LGB21...: With ionization probe or auxiliary unit AGQ1...A27 for UV detector QRA...

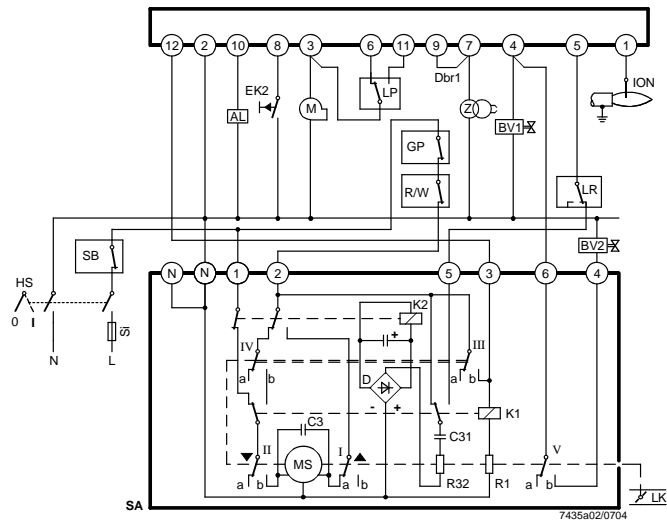
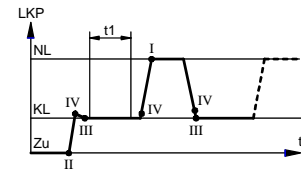
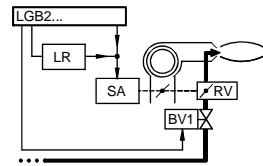
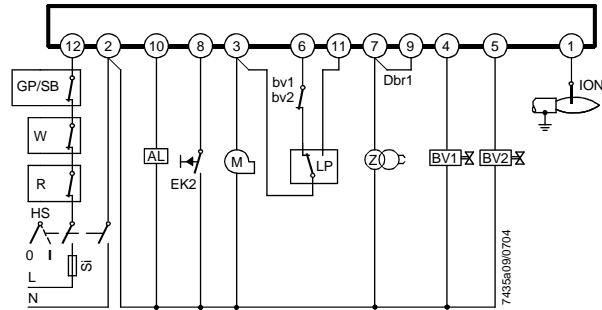

SQN91.140... / 2-stage control

Connection diagrams (cont'd)

LGB21...

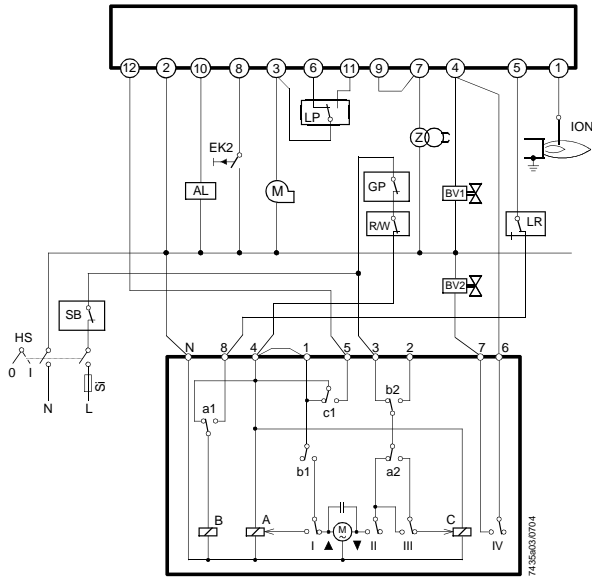

SQN7...244 / 2-stage control

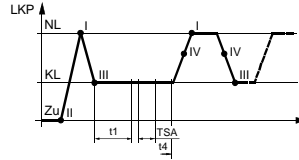

Burner without fan and **without «LP»**

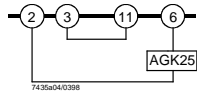

Burner with fan control via auxiliary contactor («HS») **with «LP»**

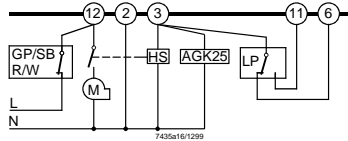

QRA... with auxiliary unit AGQ1... with LGB21... (diagram 7435a06)

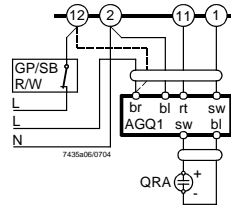

Legend

- bl Blue wire
- br Brown wire
- rt Red wire
- sw Black wire

Connection diagrams (cont'd)

LGB22... / LGB32...

Burner controls for single- or 2-stage forced draft burners.
Air damper control for prepurging with **nominal load air volume**.

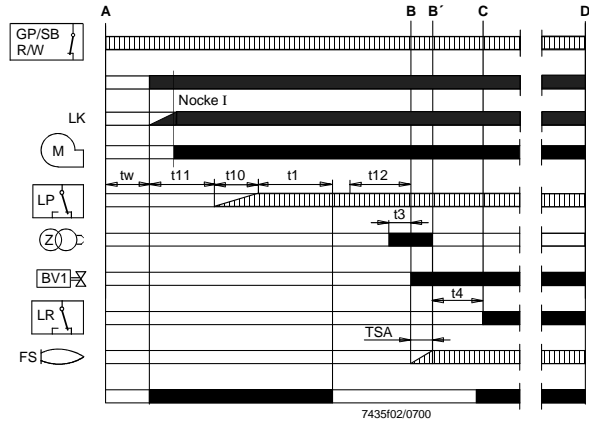

Application examples

Control of actuators of 2-stage or 2-stage modulating burners.
Purpuring («t1») with nominal load air volume.

For information about the actuators:

SQN3...: Refer to Data Sheet N7808

SQN7...: Refer to Data Sheet N7804

SQN9...: Refer to Data Sheet N7806

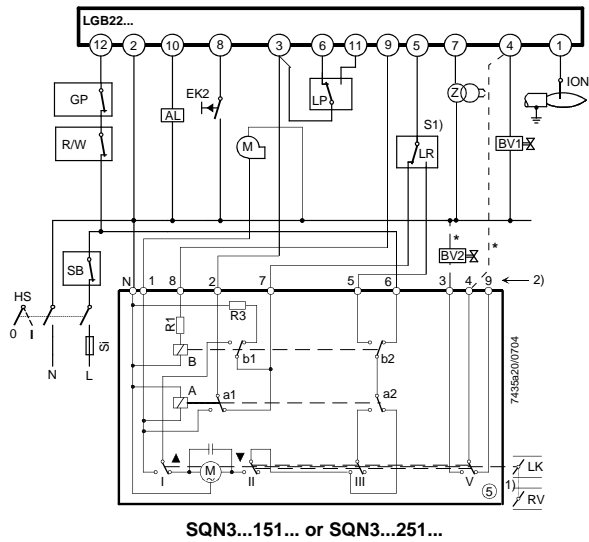

* Note:

With 2-stage modulating burners (with gas control damper «RV»), «BV2» and the dotted connection between terminals marked (*) are not required.

Flame supervision

LGB22...: With ionization probe or auxiliary unit AGQ1... for UV detector QRA...

LGB32...: With blue-flame detector QRC1...

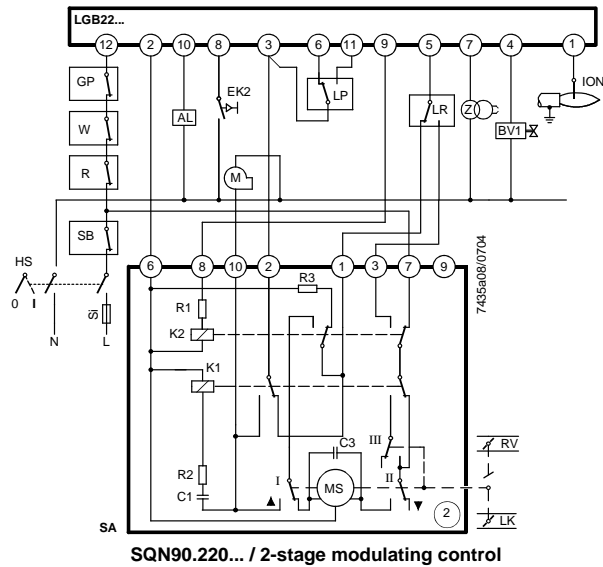
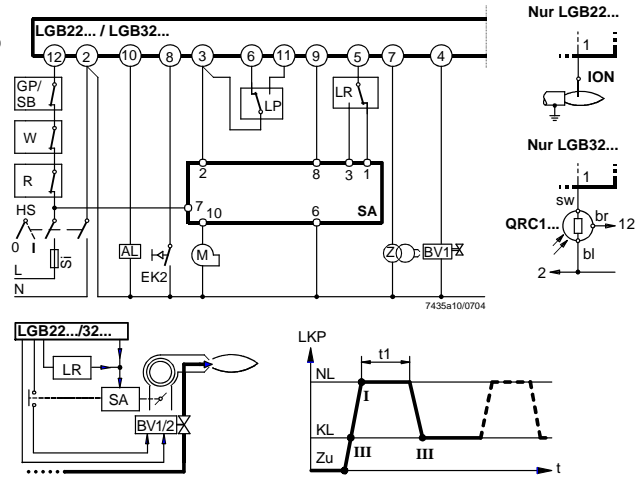

Connection diagrams (cont'd)

LGB22... / LGB32...

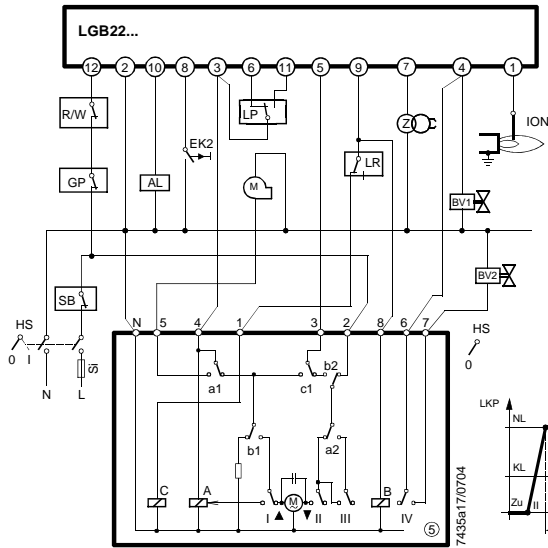

SQN7...454 / 2-stage control
Single-wire control

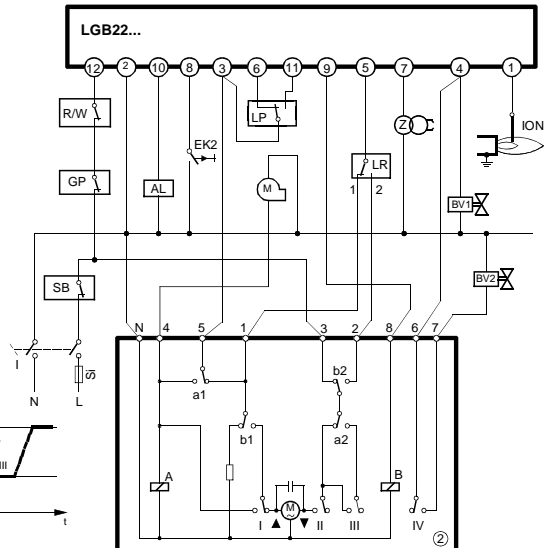

SQN7...424 / 2-stage control
2-wire control

Burner without fan and **without «LP»**

QRA... with auxiliary unit AGQ1... with LGB22... (diagram 7435a06)

LGB22... / LGB32...

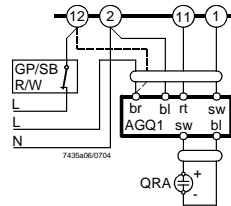
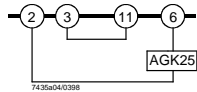

Burner with fan control via auxiliary contactor («HS») **with «LP»**

Legend

LGB22... / LGB32...

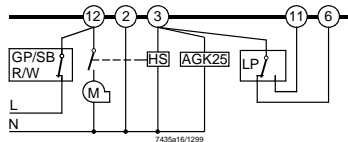

- bl Blue wire
- br Brown wire
- rt Red wire
- sw Black wire

Legend

- TSA Ignition safety time
- t1 Prepurge time
- t4 Interval «BV1 – BV2»
- LGB22... / LGB32...: interval «BV1 - LR»

- AL Alarm
- BV... Fuel valve
- EK2 Remote reset button
- ION Ionization probe
- GP Gas pressure switch
- HS Mains isolator
- KL Low-fire
- LKP Air damper position
- LP Air pressure switch
- LR Load controller
- M Fan motor
- NL Nominal load
- R Control thermostat or pressurestat
- SB Safety limit thermostat
- Si Primary fuse
- W Limit thermostat
- Z Ignition transformer

Connection diagrams (cont'd)

LGB41...

Burner controls for atmospheric gas burners with or without fan. No actuator control. Flame supervision with ionization probe

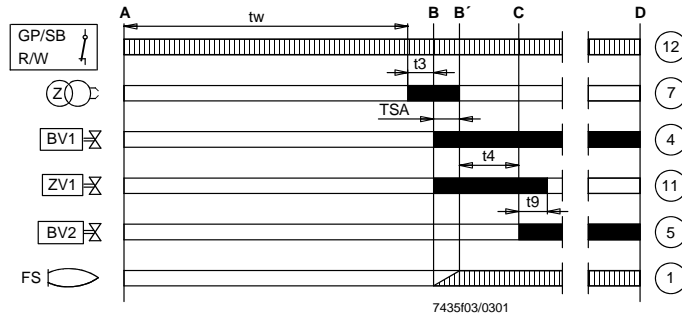

QRA... with auxiliary unit AGQ1... with LGB4... (Pictures 7435a21)

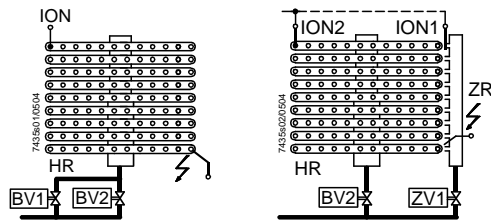
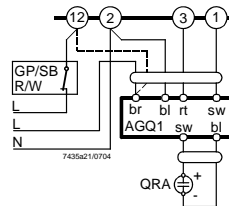
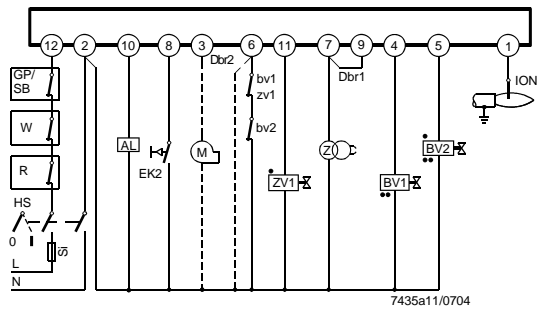

Legend

- A Startup (switching on by «R»)
- B – B' Interval for establishment of flame
- C Operation position of burner or release of the second stage by load controller «LR»
- D Shutdown by «R»

- tw Waiting time
- TSA Ignition safety time
- t3 Preignition time
- t4 Interval «BV1 – BV2»
- t9 2. safety time

- Required input signals
- Burner control's output signals

- Connection of valves with pilot burners with main flame supervision
- Connection of valves with 2-stage atmospheric burners with supervision of the first stage («BV1»)

- AL Alarm
- BV... Fuel valve
- bv... Auxiliary switch in the fuel valves (for control the closed position)
- Dbr1 Wire link
- Dbr2 Wire link, required when contacts «bv» or «zv1» is missing
- EK2 Remote reset button
- ION Ionization probe
- FS Flame signal
- GP Gas pressure switch
- HR Main ramp
- HS Main switch
- M (Auxiliary) fan motor
- QRA... UV flame detector
- QRC... Blue flame detector
- bl Blue wire
- br Brown wire
- rt Red wire
- sw Black wire
- R Control thermostat or pressurestat
- SB Safety limit thermostat
- Si Primary fuse
- W Limit thermostat
- Z Ignition transformer
- ZR Ignition ramp
- ZV1 Ignition gas valve
- zv1 Auxiliary switch in ignition gas valve

Internal diagram and time diagram of the programming mechanisms

LGB21...

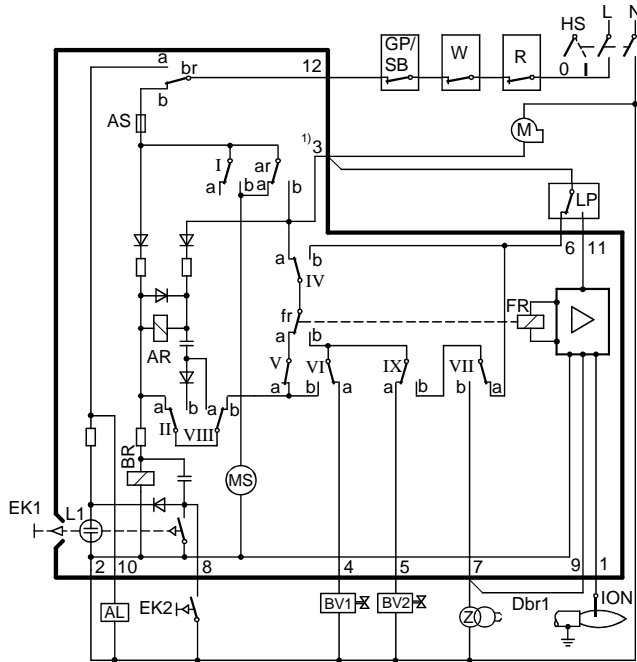

Legend

- AL Alarm
- AR Load relay with contact «ar»
- AS Unit fuse
- BR Locking relay with contact «br»
- BV... Fuel valve
- Dbr1 Wire link
- EK... Lockout reset button
- FR Flame relay
- GP Gas pressure switch
- HS Mains isolator
- ION Ionization probe
- L1 Lockout warning lamp
- LP Air pressure switch
- M Fan motor
- MS Synchronous motor
- R Control thermostat or pressurestat
- SB Safety limit thermostat
- W Limit thermostat or pressure switch
- Z Ignition transformer

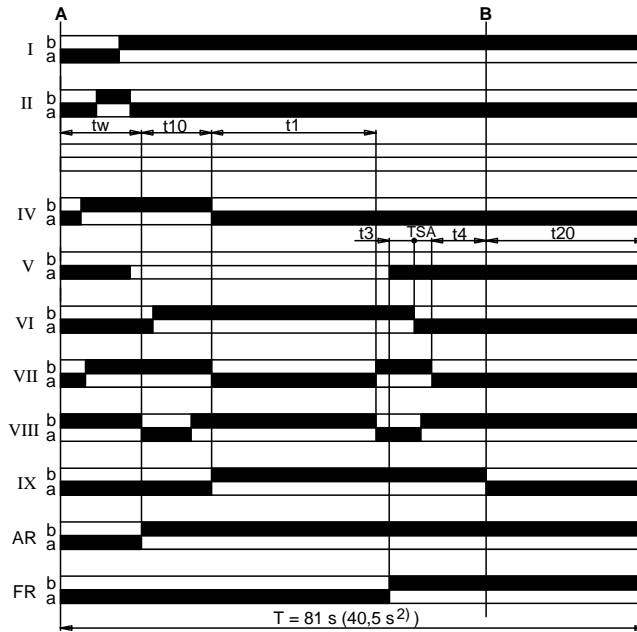

- A Start position (switching on)
- B Operating position of burner
- C Operating position of programming mechanism or start position

I...IX Cam switches

tw Waiting time

TSA Ignition safety time

T Total running time of programming mechanism

t1 Prepurge time

④ t3 Preignition time

t4 Interval «BV1 – BV2»

⑦ t10 Specified time for air pressure signal

t20 Interval up to self-shutdown of programming mechanism

⑤

1) Resistance between terminal 3 and «N» must not exceed 1.6 kΩ

③

2) Only with LGB21.130A27

Internal diagram and time diagram of the programming mechanisms (cont'd)

LGB22... / LGB32...

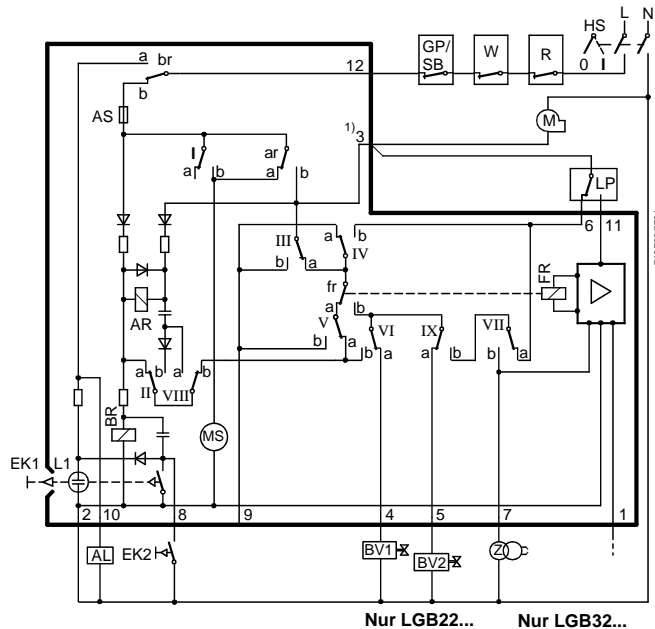

Legend

- AL Alarm
- AR Load relay with contact «ar»
- AS Unit fuse
- BR Locking relay with contact «br»
- BV... Fuel valve
- EK... Lockout reset button
- FR Flame relay
- GP Gas pressure switch
- HS Mains isolator
- ION Ionization probe
- L1 Lockout warning lamp
- LP Air pressure switch
- M Fan motor
- MS Synchronous motor
- R Control thermostat or pressurestat
- SB Safety limit thermostat
- W Limit thermostat or pressure switch
- Z Ignition transformer

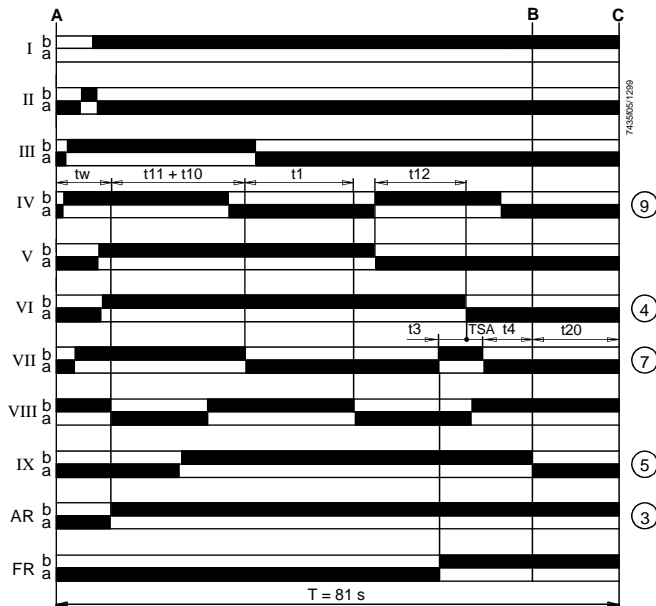
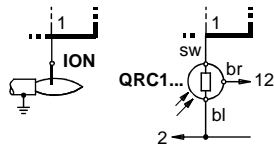

- A Start position (switching on)
 - B Operating position of burner
 - C Operating position of programming mechanism or start position
- I...IX Cam switches
 - tw Waiting time
 - TSA Ignition safety time
 - T Total running time of programming mechanism
 - t1 Pre-purge time
 - t3 Pre-ignition time
 - t4 Interval «BV1 – BV2» or «BV1 – LR»
 - t10 Specified time for air pressure signal
 - t11 Programmed opening time for actuator «SA»
 - t12 Programmed closing time for actuator «SA»
 - t20 Interval up to self-shutdown of programming mechanism
- 1) Resistance between terminal 3 and «N» must not exceed 1.6 kΩ

Internal diagram and time diagram of the programming mechanisms (cont'd)

LGB41...

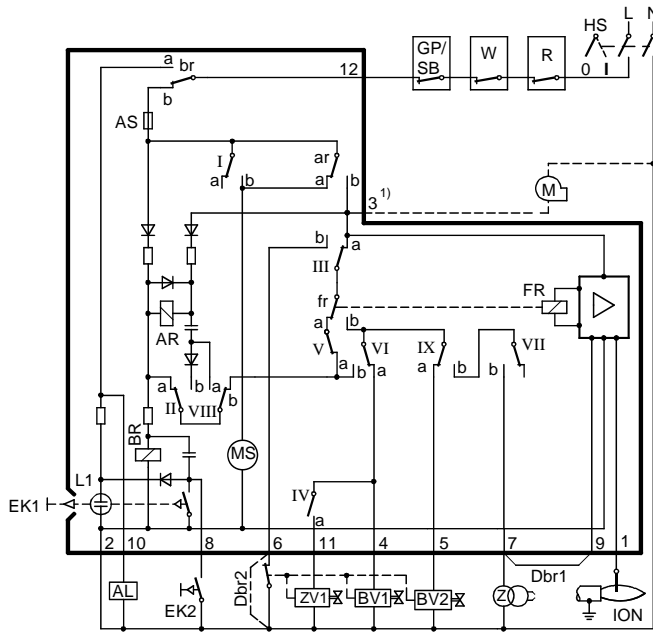

Legend

- AL Alarm
- AR Load relay with contact «ar»
- AS Unit fuse
- BR Locking relay with contact «br»
- BV... Fuel valve
- Dbr1 Wire link
- Dbr2 Wire link terminal 6-2 required when contact «bv» or «zv1» is missing
- EK... Lockout reset button
- FR Flame relay
- GP Gas pressure switch
- HR Main burner
- HS Mains isolator
- ION Ionization probe
- L1 Lockout warning lamp
- M Fan motor
- MS Synchronous motor
- R Control thermostat or pressurestat
- SB Safety limit thermostat
- W Limit thermostat or pressure switch
- Z Ignition transformer
- ZR Pilot burner
- ZV1 Pilot gas valve in place of «BV1» in the case of pilot burners with main flame supervision

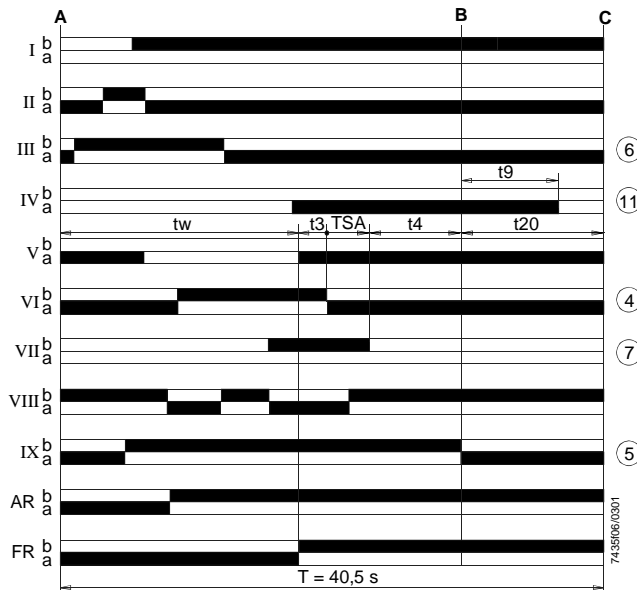

- tw Waiting time
- TSA Ignition safety time
- T Total running time of programming mechanism
- t3 Preignition time
- t4 Interval «BV1 - BV2»
- t9 Second safety time
- t20 Interval up to self-shutdown of the programming mechanism

- A Start position (switching on)
- B Operating position of burner
- C Operating position of programming mechanism or start position

I...IX Cam switches

1) Resistance between terminal 3 and «N» must not exceed 1.6 kΩ



Dimensions

Dimensions in mm

LGB...



Plug-in base
AGK11... / AGK13...

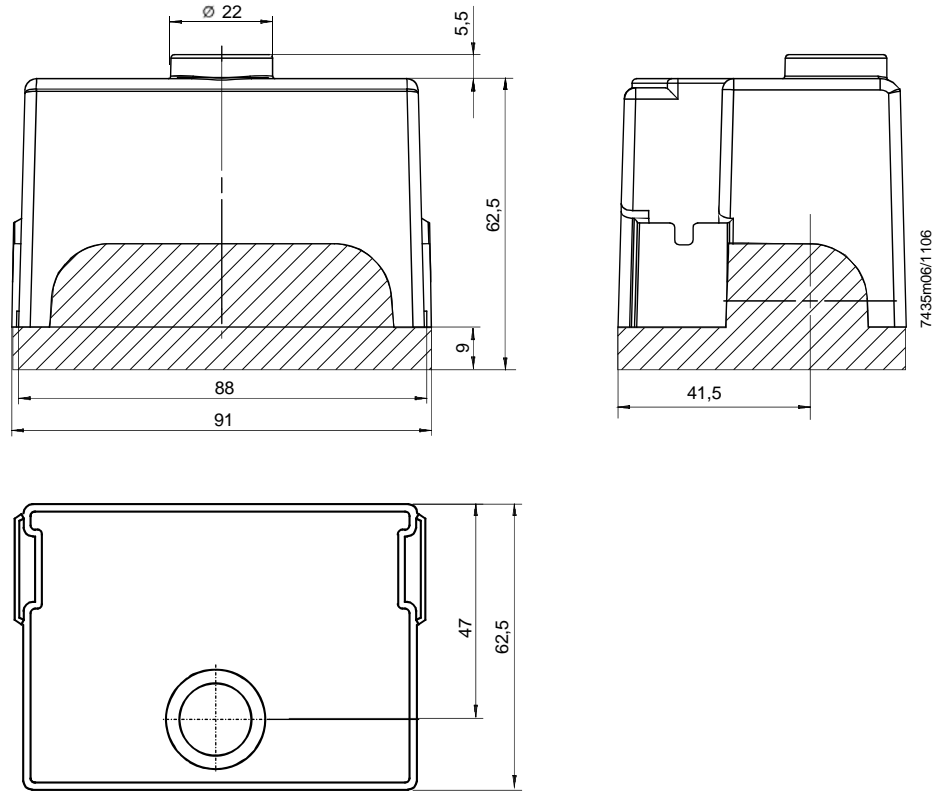

Auxiliary unit
AGQ1...A27

